

PRODUCT DATA

Charge to DeltaTron[®] Converters — Types 2647, 2647 A, 2647 B and 2647 C

FEATURES (general)

- Enables charge transducers to be used on DeltaTron power supplies. Compatible with ICP[®], ISOTRON[®], PIEZOTRON[®], CCLD, etc.
- May also be used with any DeltaTron conditioning amplifier that does not support IEEE P1451.4

FEATURES (2647 A, 2647 B and 2647 C)

- Supports “Smart Transducer Interface” IEEE P1451.4 containing TEDS (Transducer Electronic Data Sheet)
- Fixed sensitivity:
 - 2647 A, 1 mV/pC
 - 2647 B, 10 mV/pC
 - 2647 C, 0.1 mV/pC

FEATURES (2647)

- Supports “Smart Transducer Interface” IEEE P1451.4 containing TEDS (Transducer Electronic Data Sheet)
- Active mode with two gain settings
- Passive mode allows connection of up to 4 units in parallel

BENEFITS

- Setup and measurement time is reduced
- Fewer instruments in users instrument pool
- Enables plug and play between charge transducers/converter pairs
- Easier field installation and configuration
- Charge transducers can be given identification via TEDS
- Reduces human errors during measurements
- Individual production/calibration data stored in TEDS



Type No.	Gain mV/pC	Extended Functionality	Lower Limiting Frequency (-10%, -1 dB)	Upper Limiting Frequency (-10%, -1 dB)
2647	1 & 10	Yes	0.17 Hz	50 kHz
2647 A	1	No	0.17 Hz	50 kHz
2647 B	10	No	0.17 Hz	50 kHz
2647 C	0.1	No	1.0 Hz	10 kHz

Description of Types 2647 A, 2647 B and 2647 C

Types 2647 A, B and C are Charge to DeltaTron Converters intended to connect charge transducers to DeltaTron inputs. The converters are contained in small $\varnothing 7 \times 78$ mm stainless steel tubes, weighing less than 10 grams and equipped with 10–32 UNF connectors at both ends. A special mounting clip, DV 0467, is supplied and can be used to

2647

hold and insulate the converter from the supporting surface. It also prevents it from rolling about. The clips can be attached together in order to keep the measurement setup tidy.

Types 2647 A, B and C support IEEE P1451.4 “A Smart Transducer Interface for Sensors and Actuators” and contain a unique identification code and TEDS.

Types 2647 A, B and C can also be used as simple converters with 1 mV/pC (2647 A and C) or 10 mV/pC (2647 B) sensitivity in connection with DeltaTron equipment that does not support IEEE P1451.4, e.g., 8-channel DeltaTron Supply Type 5693, DeltaTron Power Supply WB 1372, Accelerometer Power Supply ZG 0328, 4-channel Input Modules for PULSE™ Types 3022 and 3023 and Measuring Amplifier Type 2525 (see Fig. 1). (Note: NEXUS and the range of Type 2694 Conditioning Amplifiers support IEEE P1451.4 for transducers only. Therefore, when using Type 2647 A, B or C with NEXUS or Type 2694, you need to enter the combined sensitivity of the charge transducer and the converter in NEXUS using the same procedure as for transducers that do not support TEDS.) Types 2647 A, B and C are delivered in boxed sets of up to 4 units.

Fig. 1
Connecting 4 ×
Types 2647 A, B and
C to a conditioning
amplifier with or
without IEEE
P1451.4 support

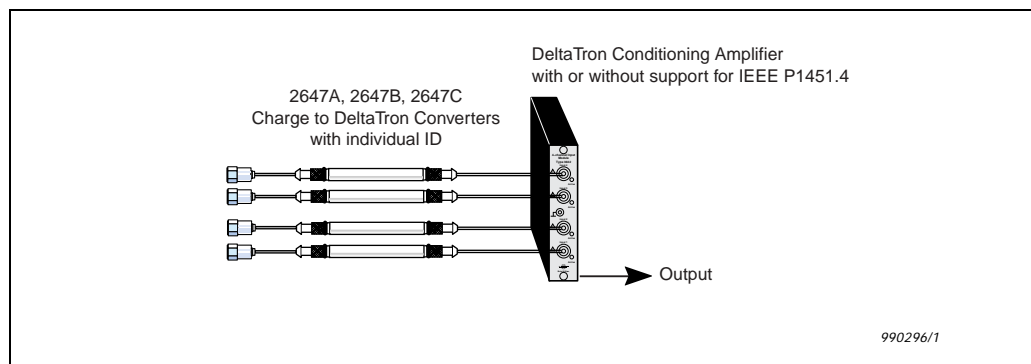

Type 2647 A has a sensitivity of 1 mV/pC, Type 2647 B 10 mV/pC and Type 2647 C 0.1 mV/pC which enables a wide range of charge accelerometers to be adapted to the vibration levels to be measured. By means of a TEDS editor (see Fig. 4), the contents of the TEDS can be read. The built-in, unique identification code (ID) enables the user to locate and verify a given converter in the measurement setup. There is also space to write a comment (up to 11 ASCII characters).

Description of Type 2647

Type 2647 is similar to Types 2647 A, B and C. The important difference is that Type 2647, besides the normal IEEE P1451.4 features, also supports extended functionality. That is, the ability to remotely set the sensitivity to either 1 or 10 mV/pC or to turn the unit off (passive, high-impedance mode, see later).

Type 2647 can also be used as a simple converter (default mode) with 1 mV/pC sensitivity in connection with DeltaTron equipment that does not support IEEE P1451.4.

Fig. 2
 Connecting 4 × Type 2647 to a single input on a IEEE P1451.4 capable conditioning amplifier with support of extended functionality i.e. the ability to control the switch in the amplifier. In this setup one Type 2647 is in active mode while the other three are in passive mode

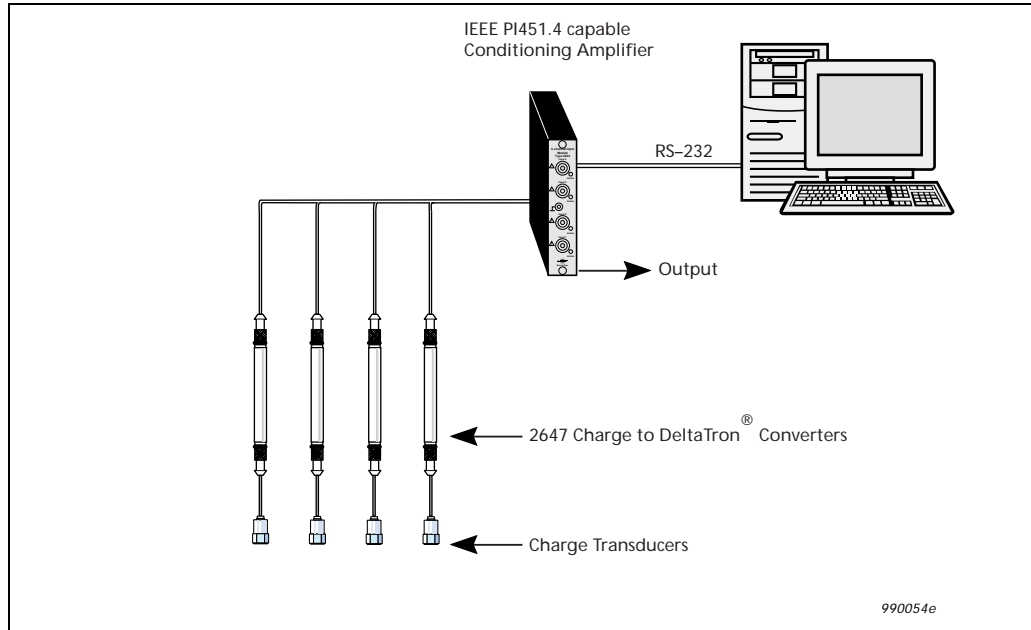
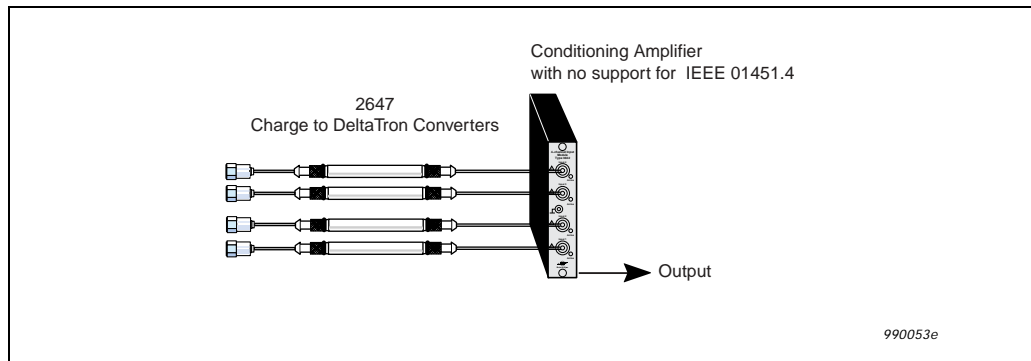

Fig. 3
 Connecting 4 × Type 2647 to a conditioning amplifier with no or limited (no extended functionality) IEEE P1451.4 support. In this default mode only the 1 mV/pC sensitivity is available



Note: The IEEE P1451.4 facilities in Type 2647 require a Demonstration Adaptor and software support from a TEDS editor installed in the host, e.g., a PC. See “Accessories” for further details.

The two gains in Type 2647 enable a wide range of charge accelerometers to be adapted to the vibration levels to be measured. The passive mode enables up to 4 converters to be connected in parallel on the same coaxial cable (see Fig. 2). By means of a TEDS editor (see Fig. 5), the signal from one of the converters can be selected and conditioned thus providing a multiplexing function. The built-in, unique identification code (ID) enables the user to locate and verify a given converter in the measurement setup. There is also space to write a comment (up to 11 ASCII characters).

IEEE P1451.4

IEEE P1451.4 proposes a mixed-mode smart transducer communication protocol based on existing analogue connections using a co-axial cable. It also specifies Transducer Electronic Data Sheets (TEDS) formats for interfacing analogue transducers with additional, smart features to legacy systems. The scope of this standard is to allow analogue transducers to communicate digital information with an IEEE P1451 object. Over 20 templates have been defined to date; the template used in Types 2647 A and B is UTID 257 (Unique Template Identification). The template in Type 2647 is UTID 385.

Fig. 4
 TEDS editor used to show the contents of the Transducer Electronic Data Sheet for Types 2647 A/B/C

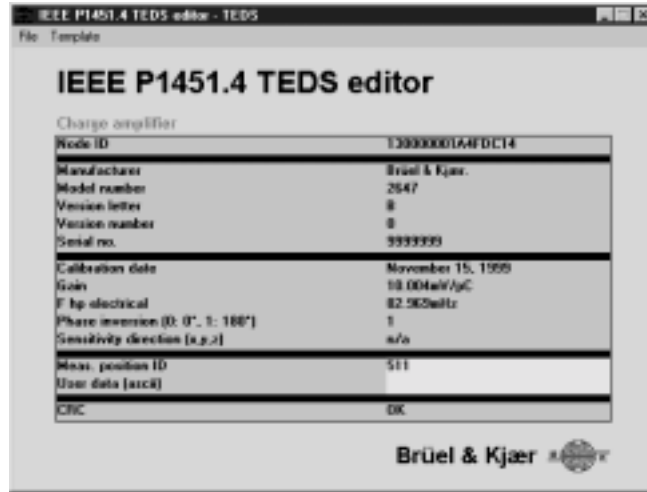

Even if the equipment does not support IEEE P1451.4 with extended functionality it is possible to make use of both gain settings. With the demo adapted UA 2019 it is possible to select the desired gain and then disconnect the 2647 and reconnect it to the measuring system within approximately 30 seconds. (Otherwise it forgets its setting and returns to the default setting of 1 mV/pC.) The measuring system must be powered up and ready to accept the device.

Fig. 5
 TEDS editor and Switch Control window used with Type 2647

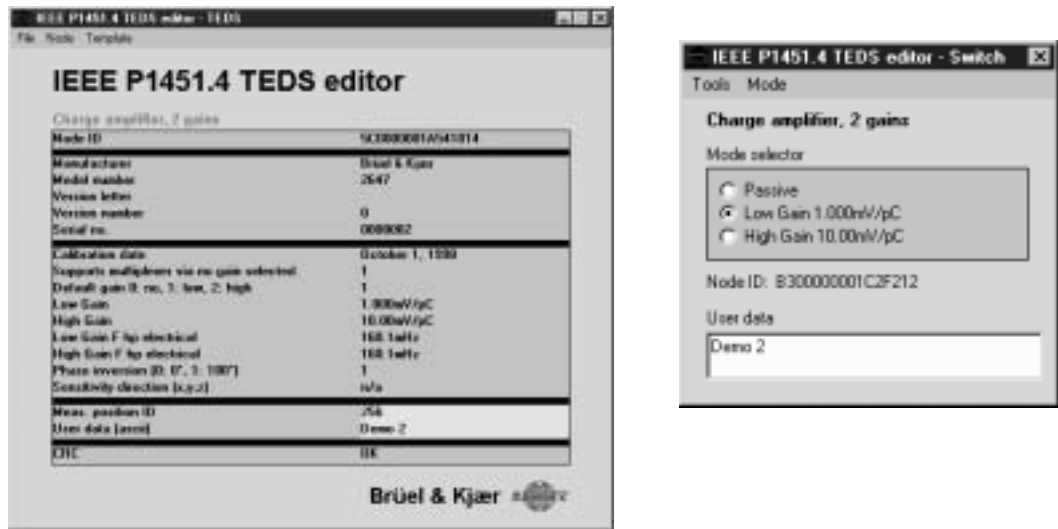

Specifications – Charge to DeltaTron Converters Types 2647, 2647 A/B/C

Common Specifications

INPUT

- Coaxial (10–32 UNF) female, stainless steel
- Single ended for piezoelectric charge transducers
- Protected to max. 300nC peak, and against input/output reversal (input marked with a ring)

OUTPUT

- Coaxial (10–32 UNF) female, stainless steel
- Single ended DeltaTron

Current Range: 4–20 mA

Supply Voltage (Unloaded): 24 to 28 VDC for full specification range and 18 VDC with reduced measuring range

Bias Voltage: 13 V \pm 1 V over the full temperature and current range

Max. Output Voltage Swing: 14 V Peak to Peak

Output Impedance: < 40 Ω

ENVIRONMENTAL

Susceptibility to Vibration (10– 500 Hz): Typ. <50 μ V/ms⁻² referred to output

Susceptibility to 50/60 Hz Magnetic Fields: <30 mV/T (3 μ V at 80 A/m) referred to output

Radiation: 10⁴ RAD (γ) non-destructive

MECHANICAL

Dimensions: \varnothing 7 \times 78 mm (\varnothing 0.27 \times 3.07 in)

Case: Stainless steel tube

Weight: Max. 10 grams (0.35 oz.)

2647 A, 2647 B and 2647 C

TRANSFER

Nominal Sensitivity:

2647 A: 1 mV/pC \pm 2.5%

2647 B: 10 mV/pC \pm 2.5%

2647 C: 0.1 mV/pC \pm 2.5%

The actual sensitivity values as delivered from production are present in the TEDS

Temperature Coefficient: 0 \pm 100 ppm/K.

Inherent Noise Voltage Referred to Input: (at 1nF input load capacitance):

	0.1 mV/pC	1 mV/pC	10 mV/pC
1 Hz–22.4 kHz	Typ. 300 μ V	Typ. 10 μ V	Typ. 6 μ V
22.4 Hz–22.4 kHz	< 40 μ V, Typ. 2.5 μ V	< 8 μ V, Typ. 4.5 μ V	< 5 μ V, Typ. 2.5 μ V

Inherent Noise Voltage Density Referred to Input: (at 1nF input load capacitance):

0.1 mV/pC	1 mV/pC	10 mV/pC
Typ. 6 μ V/Hz ^{1/2}	Typ. 400 nV/Hz ^{1/2}	Typ. 200 nV/Hz ^{1/2} at 10 Hz
Typ. 400 nV/Hz ^{1/2}	Typ. 100 nV/Hz ^{1/2}	Typ. 50 nV/Hz ^{1/2} at 100 Hz
Typ. 250 nV/Hz ^{1/2}	Typ. 50 nV/Hz ^{1/2}	Typ. 25 nV/Hz ^{1/2} at 1 kHz

Lower Limiting Frequency: (1st order, –10%) 2647 A and B Typ. 0.17 Hz at 1nF transducer capacitance; 2647 C Typ. 1.0 Hz

Upper Limiting Frequency: (–10%) > 50 kHz at 1nF transducer capacitance, 4 mA supply current and 2 V Peak out (2647 A and B) Type 2647 C Typical 10 kHz at 1.5 nF input load, 4 mA supply current and 2 V peak out.

Phase: Inverted

Phase Match: 2647 A and B \pm 1° (3 Hz–1 kHz), 2647 C \pm 1° (15 Hz–200 Hz) between units with same range selected and with same environmental conditions

THD (2 Hz–22 kHz): <0.1% at 1 V RMS output

Recovery Time from Overload:

<100 s at 10 mV/pC sensitivity, (bias within \pm 1 V of final value)

<10 s at 1 mV/pC sensitivity, (bias within \pm 1 V of final value)

<2 s at 0.1 mV/pC sensitivity, (bias within \pm 1 V of final value)

IEEE P1451.4

Includes ID and TEDS

User Comment Field: 11 ASCII characters

2647

TRANSFER

Sensitivity: Nominal 1 or 10 mV/pC \pm 2.5% (Remote selectable)
The actual sensitivity values as delivered from production are present in the TEDS

Temperature Coefficient: 0 \pm 100 ppm/K

Default Sensitivity: 1 mV/pC (with no IEEE P1451.4 support or when first powered on)

Inherent Noise Voltage Referred to Input: (at 1nF input load capacitance):

	1 mV/pC	10 mV/pC
1 Hz–22.4 kHz	Typ. 20 μ V	Typ. 12 μ V
22.4 Hz–22.4 kHz	< 10 μ V, Typ. 6 μ V	< 7 μ V, Typ. 4 μ V

Inherent Noise Voltage Density Referred to Input: (at 1nF input load capacitance):

1 mV/pC	10 mV/pC
Typ. 800 nV/Hz ^{1/2}	Typ. 400 nV/Hz ^{1/2} at 10 Hz
Typ. 200 nV/Hz ^{1/2}	Typ. 100 nV/Hz ^{1/2} at 100 Hz
Typ. 100 nV/Hz ^{1/2}	Typ. 50 nV/Hz ^{1/2} at 1 kHz

Lower Limiting Frequency: (1st order, –10%) Typ. 0.17 Hz at 1nF transducer capacitance

Upper Limiting Frequency: (–10%) > 50 kHz at 1nF transducer capacitance, 4 mA supply current and 2 V Peak out

Phase: Inverted

Phase Match: \pm 1° (3 Hz–1 kHz) between units with same range selected and with same environmental conditions

THD (2 Hz–22 kHz): <0.1% at 1 V RMS output

Crosstalk between an Active and a Passive Unit: Typ. < –100 dB at 20 kHz

Recovery Time from Overload:

<100 s at 10 mV/pC sensitivity, (bias within \pm 1 V of final value)

<10 s at 1 mV/pC sensitivity, (bias within \pm 1 V of final value)

EXTENDED FUNCTIONALITY

Sensitivity Selection: 1 mV/pC, 10 mV/pC Passive Mode Selection (e.g., for parallel connection of units)



Current Consumption in Passive Mode: <200 μ A

IEEE P1451.4

Includes ID, TEDS and Extended Functionality

User Comment Field: 11 ASCII characters

Compliance with Standards

 	CE-mark indicates compliance with: EMC Directive and Low Voltage Directive. C-Tick mark indicates compliance with the EMC requirements of Australia and New Zealand.
Safety	EN 61010-1 & IEC 61010-1: Safety requirements for electrical equipment for measurement, control and laboratory use. UL 3111-1: Electrical Measuring and Test Equipment.
EMC Emission	EN 50081-1 & IEC 61000-6-3: Generic emission standard. Part 1: Residential, commercial & light industry. EN 50081-2 & IEC 61000-6-4: Generic emission standard. Part 2: Industrial environment. EN/IEC 61326: Equipment for measurement, control and laboratory use. CISPR 22: Radio disturbance characteristics of information technology equipment. Class B Limits. FCC Rules, Part 15: Complies with the limits for a Class B digital device.
EMC Immunity	EN 50082-1 & IEC 61000-6-1: Generic immunity standard. Part 1: Residential, commercial & light industry. EN 50082-2 & IEC 61000-6-2: Generic immunity standard. Part 2: Industrial environment. EN/IEC 61326: Equipment for measurement, control and laboratory use. Note 1: Refer to "Environmental Susceptibility" in specifications. Note 2: The above is guaranteed using the accessories in this PD sheet only.
Temperature	IEC 68-2-1 & IEC 68-2-2: Environmental Testing. Cold and Dry Heat. Operating Temperature: -40 to +85°C (-40 to +185°F) Storage Temperature (in box): -40 to +85°C (-40 to +185°F) IEC 68-2-14: Change of Temperature: -10 to +55°C (2 cycles, 1°C/min.)
Humidity	IEC 68-2-3: Damp Heat: 90% RH (non-condensing at 40°C (104°F))
Mechanical	Operating (peak values) MIL-STD-819C: Vibration: 12.7 mm, 15 m/s ² , 5 – 500 Hz Non-operating: IEC 60068-2-6: Vibration: 1 mm, 150 m/s ² , 10 – 500 Hz IEC 60068-2-27: Shock: 30 km/s ² /250 µs IEC 60068-2-29: Bump: 4000 bumps at 400 m/s ² IEC 60068-2-32: Drop: 10 times in 3 directions
Enclosure	IEC 60529 (1989): Protection provided by enclosures: IP43

Ordering Information

Type 2647	Charge to DeltaTron Converter (1 mV/pC and 10 mV/pC)	AO 0463*	Cable AC 0208 with 10 – 32 UNF connectors, 1.2 m (4 ft) – 5 to 70°C (23 to 158°F)
Type 2647 A	Charge to DeltaTron Converter (1 mV/pC)	AO 0038*	Super low-noise Teflon cable, AC 0005 with 10 – 32 UNF connectors, 1.2 m (4 ft) 250°C (482°F)
Type 2647 B	Charge to DeltaTron Converter (10 mV/pC)	AO 0122	Reinforced super low-noise cable, AC 0200 with 10 – 32 UNF connectors, 3 m (10 ft) 250°C (482°F)
Type 2647 C	Charge to DeltaTron Converter (0.1 mV/pC)	AO 0406	Double-screened low-noise cable AC 0104 with 10 – 32 UNF connectors, 5 m (16 ft). Includes adaptor JP 0145 250°C (482°F)
Include the following accessories:		AO 1419*	Low-noise cable AC 0066 with 10 – 32 UNF connectors, 1.2 m (4 ft) 250°C (482°F)
KE 4317	Carrying Box	AO 1382	Low-noise, double-screened Teflon cable AC 0104 with 10 – 32 UNF connectors, 1.2 m (4 ft) 200°C (392°F)
DV 0476	Mounting Clip (8 units included)		

Cables AO 0038, AO 0122, AO 0463 and AO 1382 are available in other lengths with 10 – 32 UNF connectors
Other values available on request. Please contact Brüel & Kjær.

Optional Accessories

BZ 5294	TEDS Editor
UA 2019	Demonstration Adaptor
UA 1555	Adaptor 10 – 32 UNF to BNC
UA 2025	Bag of 24 Mounting Clips DV 0476
AO 0531*	Cable AC 0208 with 10 – 32 UNF to BNC connectors, 5 m (16.4 ft) – 5 to 70°C (23 to 158°F)

TRADEMARKS

DeltaTron is a registered trademark, and NEXUS and PULSE are trademarks of Brüel & Kjær Sound and Vibration Measurement A/S
ICP is a registered trademark of PCB Piezotronics
ISOTRON is a registered trademark of Endevco Corporation
PIEZOTRON is a registered trademark of Kistler Instrumente AG

Brüel & Kjær reserves the right to change specifications and accessories without notice.